

LUG TYPE BUTTERFLY VALVE Z 014-A



Lug type butterfly valve with threaded holes. This type enables the one-sided lugging of pipes.

TECHNICAL DATA

Nominal diameter:	DN 20 – DN 600 (DN 20 only PN10/16)
Face-to-face:	EN 558 Series 20 (DIN 3202 T3 K1) ISO 5752 Series 20 API 609 Table 1 BS 5155 Series 4 NF E 29-305.1
Flange accommodation:	DIN 2501 PN 6/10/16 ANSI B 16.5, Class 150 MSS SP44 Class 150 AWWA C 207 AS 2129 Table D and E BS 10 Table D and E JIS B 2211-5 K JIS B 2212-10 K
Lap-joint flange:	DIN 2641 and DIN 2642
Weld-on flange:	DIN 2576
Flange Surface Design:	DIN 2526 Form A-E, ANSI RF
Top flange:	EN ISO 5211 NF E 29-402
Marking:	DIN EN 19
Tightness check:	DIN 3230 T3 BO, BN (Leakage Rate 1) ISO 5208, Category 3 API 598 Table 5 ANSI B 16-104, Class VI
Temperature range:	-20 °C to +160 °C (depending on pressure, medium and material)
Operating pressure:	max. 16 bar
Differential pressure:	max. Δp 16 bar
Vacuum:	0,2 bar absolute (depending on medium and temperature)

FEATURES

- Absolutely tight sealing with flow in either direction
- The valve body and disc are accurately machined which results in low operating torque and long service life and reliability.
- Triple shaft bearings prevents shaft deflection and guarantees optimum guidance even after many years of operating service.
- Can be disassembled, material-specific recycling possible.
- Single flange mounting is possible.
- Can be installed in any desired position.
- Maintenance-free
- Fully repairable valve

GENERAL APPLICATIONS

- Chemical and petrochemical industries
- Water and wastewater technology
- Pneumatic materials handling technology
- Shipbuilding
- Power generation industry
- Food industry
- Civil engineering
- For paint and laquers, a silicon-free Version is available.

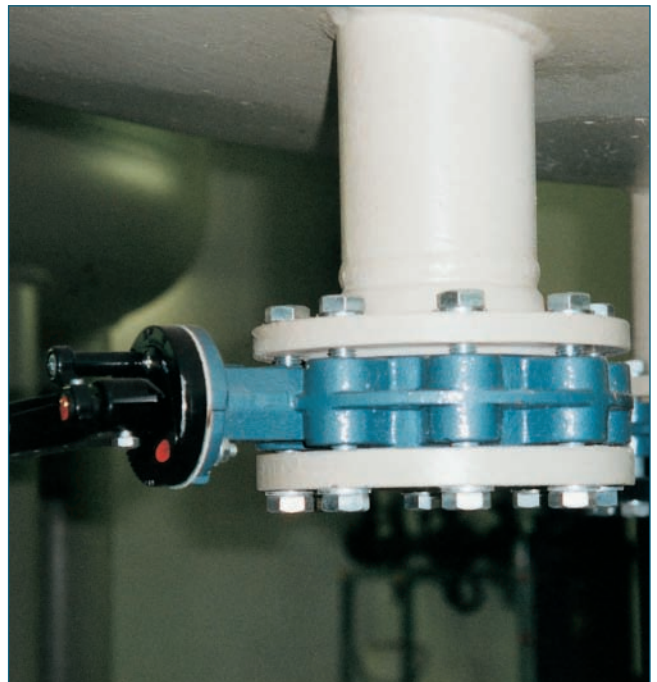

LUG TYPE BUTTERFLY VALVE Z 014-A

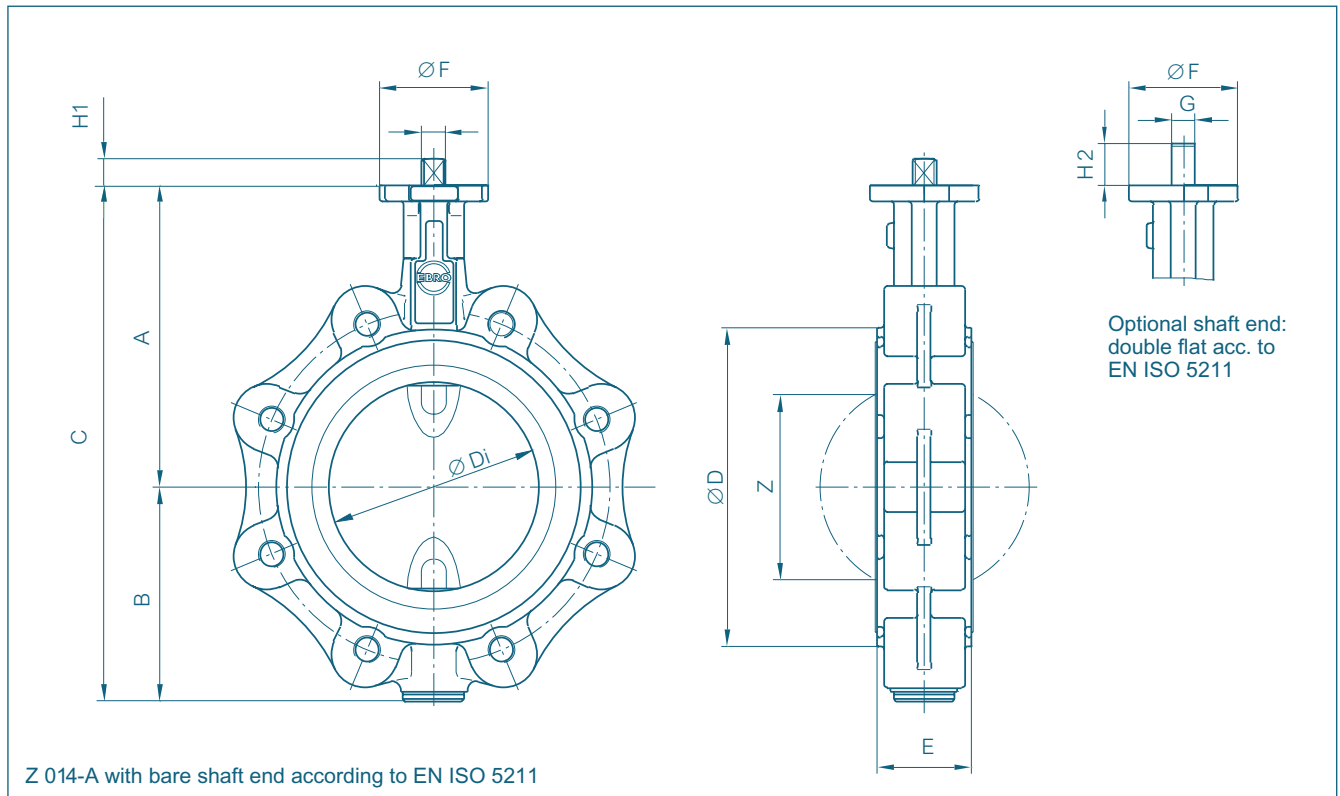

DN [mm]	Size [in]	Dimensions [mm]													Weight [kg] (GG-25)	
		A	B	C	D	Di	E	F	Flange	G	H1	H2	Z	splitted Shaft	TS- Shaft	
20	¾	104	45	149	63	31,5	33	54	F04	11	12	19	–	2,1	–	
25	1	104	45	149	63	31,5	33	54	F04	11	12	19	–	2,1	–	
32	1¼	104	50	154	68	31,5	33	54	F04	11	12	19	–	2,1	–	
40	1½	113	66	179	80	38	33	54	F04	11	12	19	22	4,0	–	
50	2	126	84	210	95	48,5	43	54	F04	11	12	19	25	4,8	–	
65	2½	134	93	227	115	63,5	46	54	F04	11	12	19	45	5,5	–	
80	3	157	104	261	138	78,5	46	65	F05	14	16	25	65	8,6	9,1	
100	4	167	115	282	158	98,5	52	65	F05	14	16	25	85	9,8	10,4	
125	5	180	127	307	188	123,5	56	65	F05	14	16	25	111	10,1	10,7	
150	6	203	150	353	210	148	56	90	F07	17	19	30	139	13,1	14,6	
200	8	228	176	404	268	199	60	90	F07	17	19	30	190	18,8	20,6	
250	10	266	212	478	320	248	68	125	F10	22	24	39	240	29,5	32,5	
300	12	291	237	528	370	296	78	125	F10	22	24	39	287	37,0	40,5	
350	14	332	269	601	408	338	78(92)**	150	F12	*	*	–	330	54,8	60,4	
400	16	363	314	677	470	388	102	150	F12	*	*	–	378	81,5	87,3	
450	18	397	335	732	530	430,5	114	210	F14	*	*	–	417	101,4	105,9	
500	20	437	405	842	574	494,5	127	210	F14/F16	*	*	–	474	136,3	142,8	
600	24	498	469	967	675	590	154	300	F16/F25	*	*	–	563	240,5	267,5	

* according to the mounted actuator
 ** face to face dim. to EN 558 Tab. 20 (92 mm)

Subject to change without notice.

ACTUATORS Z 014-A

HAND LEVER

DN [mm]	Size [in]	Hand Lever	F	H	L	Weight [kg]
20- 65	¾-2½	Size I	54	70	155	0,1
80-125	3-5	Size II	65	80	195	0,15
150-200	6-8	Size III	90	100	276	0,5

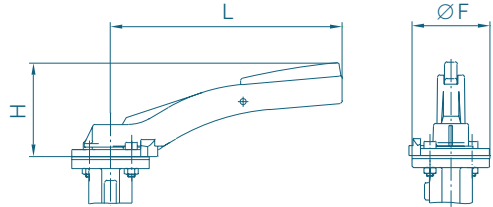

WORM GEAR

DN [mm]	Size [in]	Gear	H	J	K	L	Weight [kg]
20-65	¾-2½	Size I	89	39	125	152	1,9
80-125	3-5	Size II	89	39	125	159	1,4
150-200	6-8	Size III	129	47	200	202	2,3
250	10	Size IV	129	60	200	252	2,8
300-350	12-14	Size V	158	76	250	280	6,3
400-450	16-18	Size VI	228	90	356	322	16,0
500	20	Size VII	278	123	457	406	30,5
600	24	Size VIII	355	154	610	466	45,0

The dimensioning of actuators refers to an operating pressure of 10 bar.

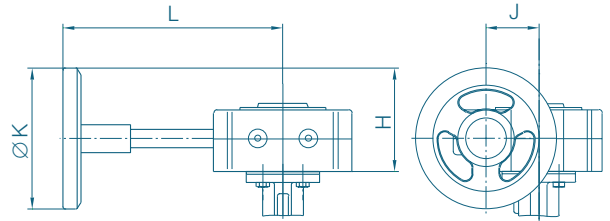

ELECTRIC ACTUATOR

DN [mm]	Size [in]	Actuator Type	H	J	K	L	M	Weight [kg]
20- 80	¾-3	E 50	210	149	80	124	110	5,0
100-150	4-6	E 65	233	172	80	139	119	7,0
200-250	8-10	E 110	251	245	125	139	134	14,0
300-350	12-14	E 160	239	279	198	139	157	25,0
400-500	16-20	E 210	276	369	315	139	215	40,0

The dimensioning of actuators refers to an operating pressure of 10 bar.

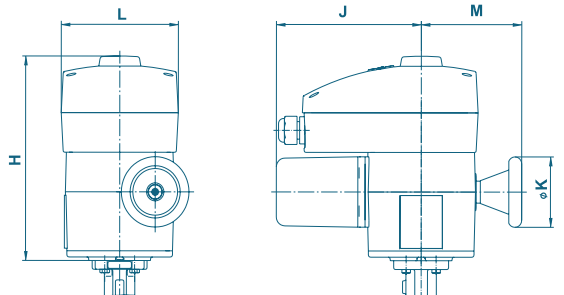

Other Actuators: See Documentation of the Manufacturer.

Subject to change without notice.

ACTUATORS Z 014-A

PNEUMATIC DOUBLE ACTING

DN [mm]	Size [in]	Actuator	H	J	K	L	Weight [kg]
20-65	3/4-2 1/2	EB4	96	74	49	145	1,1
80-125	3-5	EB5	108	88	55	174	1,7
150	6	EB6	123	103	62	208	2,6
200	8	EB8	136	115	68	250	4,3
250-300	10-12	EB10	155	135	79	312	6,8
350-450	14-18	EB12	182	159	94	367	12,0
500	20	EB265	232	152	76	390	18,0
600	24	EB270	278	220	110	445	32,0

The dimensioning of actuators refers to the following operating conditions:

Control air Pressure: 6 bar
 Operating Pressure: DN 20 - DN 300 10 bar
 DN 350 6 bar
 DN 400 - DN 600 3 bar
 Dimensioning for other conditions: upon request

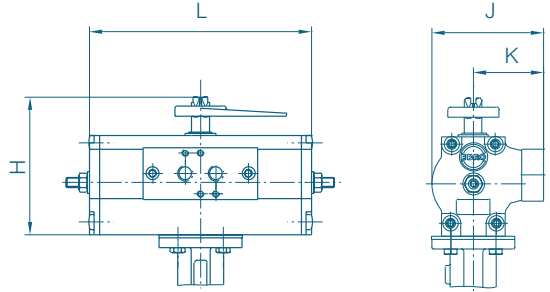

PNEUMATIC SPRING RETURN

DN [mm]	Size [in]	EBF Actuator	H	J	K	L	Weight [kg]
20-100	3/4-4	EB5	108	88	55	273	3,0
125	5	EB6	123	103	62	326	5,0
150	6	EB8	136	115	68	389	7,7
200	8	EB10	155	135	79	526	14,3
250-300	10-12	EB12	182	159	94	658	25,4
350-400	14-16	EB270	278	220	110	655	45,0
450-600	18-24	EB280	278	220	110	1020	68,0

The dimensioning of actuators refers to the following operating conditions:

Control air Pressure: 6 bar
 Operating Pressure: DN 20 - DN 300 10 bar
 DN 350 6 bar
 DN 400 - DN 600 3 bar
 Dimensioning for other conditions: upon request

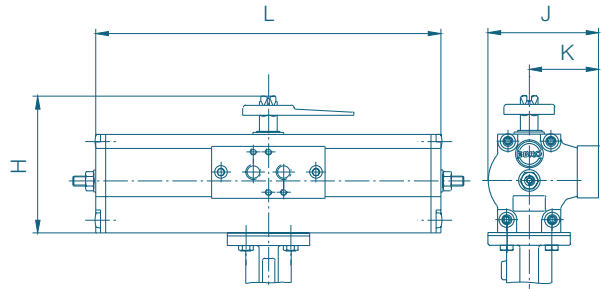

SWITCH BOX SERIES MSK/NSK

MSK: Switch box with integrated micro limit switches.
 NSK: Switch box with integrated proximity switches.

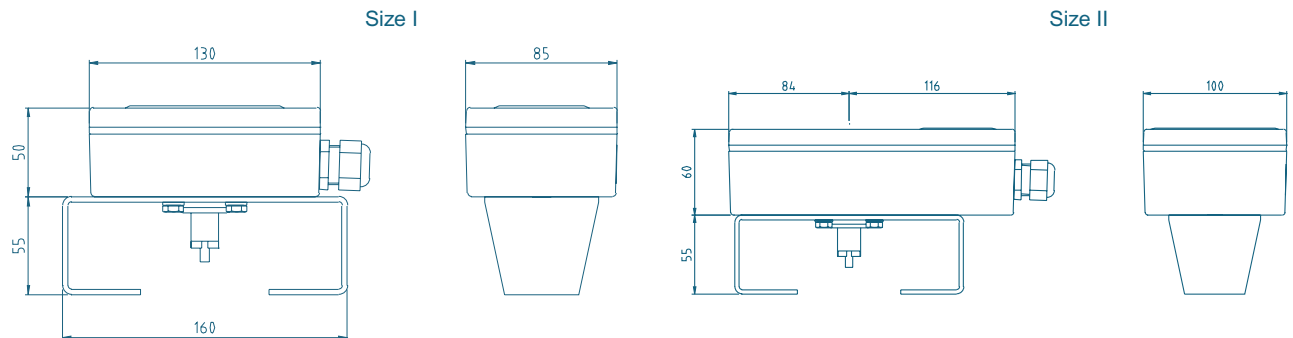

Other Actuators: See Documentation of the Manufacturer.

Subject to change without notice.

LUG TYPE BUTTERFLY VALVE Z 014-A

MATERIAL SPECIFICATION AND PARTS LIST

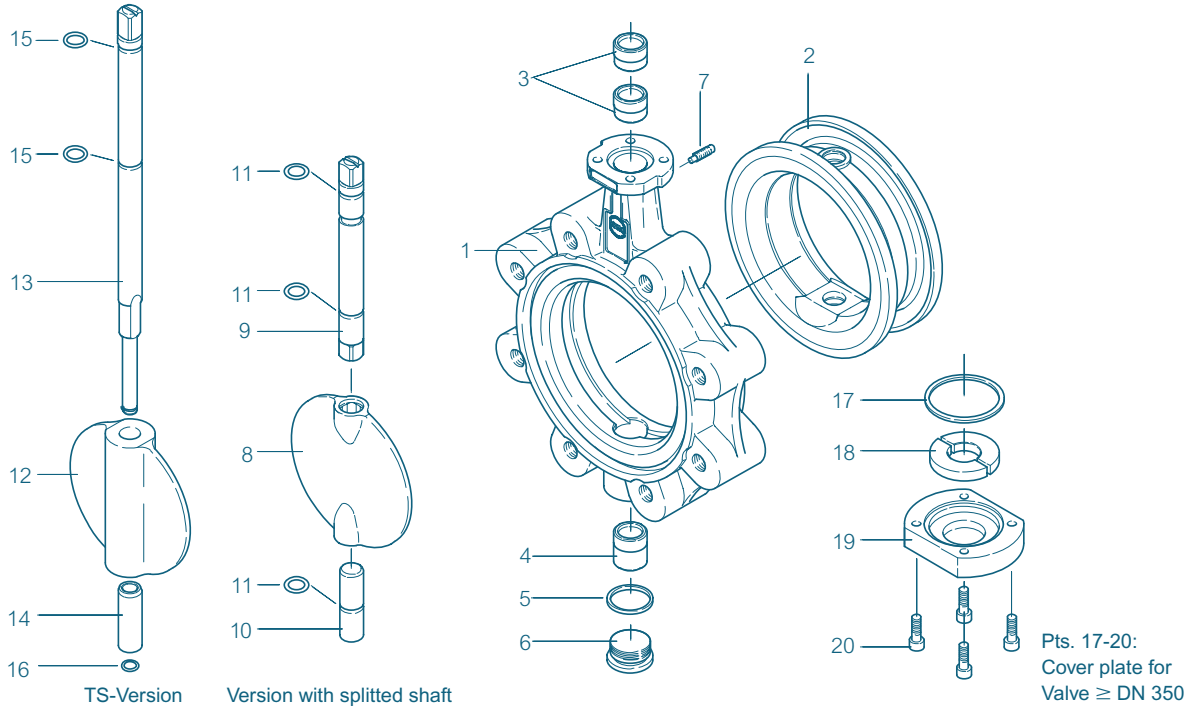

Pt.	Description	Material	Material-No.	ASTM	Pt.	Description	Material	Material-No.	ASTM
1	Body				9/10	Shafts			
	Nodular Cast Iron	GGG-40	0.7040	60-40-18		Stainless Steel	X14CrMoS17	1.4104	430F
		GGG-40.3	0.7043				X5CrNiMo17-12-2	1.4401	316
							Hastelloy	2.4883	Hastelloy
2	Seat				11	O-ring			
	NBR	Acrylonitrile butadiene rubber				NBR	Acrylonitrile butadiene rubber		
	EPDM	Ethylene propylene caoutchouc				FPM	Fluorocarbon caoutchouc		
	CSM	Chlorsulphonated polyethylene			12	TS-disc			
	FPM	Fluorocarbon caoutchouc				Nodular Cast Iron	GGG-40	0.7040	60-40-18
	VSI	Silicon rubber				Stainless Steel	G-X5CrNiMo19-11-2	1.4408	CF8M
	AU	Polyurethane elastomer				Aluminium Bronze	G-CuAl10Ni	2.0975	C 95800
3/4	Bearing bush					Coating	Halar, Rilsan		
	Brass	MS 58	2.0401	B45		Surface Quality	electropolished, mirror finished		
	Polyamide	PA 66			13	TS-shaft			
	PTFE	Polytetrafluorethylen				Stainless Steel	X14CrMoS17	1.4104	430F
5	Seal DIN 7603						X39CrMo17-1	1.4122	
	Copper	Cu		Copper			X5CrNiMo17-12-2	1.4401	316
6	Plug screw DIN 908				14	Sleeve			
	Stainless Steel	G-X5CrNiMo19-11-2	1.4408	CF8M		Stainless Steel	X5CrNi18-10	1.4301	304
7	Set screw DIN 915				15	O-ring			
	Steel	45 H galvanized				NBR	Acrylonitrile butadiene rubber		
	Stainless Steel	A4-70		B8M		FPM	Fluorocarbon caoutchouc		
8	Disc				16	Retaining ring			
	Steel	ST 52.3	1.0570	572-50		Stainless Steel	X39CrMo17-1	1.4122	
	Stainless Steel	X5CrNi18-10	1.4301	304	17	O-Ring			
		G-X5CrNiMo19-11-2	1.4408	CF8M		NBR	Acrylonitrile butadiene rubber		
		X2CrNiMo17-12-2	1.4404	316 L	18	Shaft retainer			
		X6CrNiMoTi17-12-2	1.4571	316 Ti		Brass	MS 58	2.0401	B45
		G-X2CrNiMoN26-7-4	1.4469	F 51	19	Cover plate			
		Hastelloy	2.4883	Hastelloy		Grey Cast Iron	GG-25	0.6025	40 B
	Aluminium Bronze	G-CuAl10Ni	2.0975	C 95800	20	Screw			
	Coating	Halar, Rilsan				Steel	45 H galvanized		
	Surface Quality	electropolished, mirror finished				Stainless Steel	A2-70		B8
							A4-70		B8M
									Other materials upon request.

Subject to change without notice

LUG TYPE BUTTERFLY VALVE Z 014-A

TORQUE

- The torque values specified (MD) are based on liquid and lubricant media.
 - Powdery (non-lubricant) media
Md x 1,3
 - Dry gases/high viscous media
Md x 1,2
 - The values specified are based on the initial breakaway torque.
 - Dynamic torque specification available upon request.
- Regarding the dimensioning of actuators, please contact our engineers.

DN [mm]	Size [in]	Operating pressure			
		3 [bar]	6 [bar]	10 [bar]	16 [bar]
20	3/4	–	–	5	–
25	1	–	–	5	–
32	1 1/4	–	–	5	–
40	1 1/2	–	–	6	8
50	2	5	7	7	9
65	2 1/2	7	9	15	18
80	3	8	10	18	24
100	4	9	18	28	37
125	5	15	22	45	59
150	6	36	45	110	125
200	8	59	76	140	200
250	10	150	180	200	240
300	12	200	240	280	360
350	14	350	540	610	700
400	16	420	620	750	850
450	18	720	746	860	1500
500	20	900	1100	2255	3690
600	24	1050	2100	3000	5830

All Values in Nm

K_V-VALUES

- The K_V-value (m³ per hour) is the flow of water at a temperature of 5 °C to 30 °C (41 °F to 86 °F) at Δp of 1 bar.
 - The K_V-values specified are based on tests carried out by the Delfter Hydraulics Laboratories, the Netherlands.
 - Permissible velocity of flow
V_{max} 4,5 m/s for liquids and
V_{max} 70 m/s for gases.
 - The throttle function is linear at an angle 30° to 70°.
 - Avoid cavitation!
- For further values, please contact our engineers.

DN [mm]	Size [in]	Opening angle α°							
		20°	30°	40°	50°	60°	70°	80°	90°
20	3/4	–	1	4	8	11	19	27	32
25	1	–	1,5	5	10	15	24	32	36
32	1 1/4	–	1,5	5	11	16	27	35	40
40	1 1/2	–	2,2	8	15	21	33	43	50
50	2	1,2	8	13	22	38	50	65	85
65	2 1/2	2	9	22	42	77	115	170	215
80	3	8	24	50	95	150	240	330	420
100	4	13	28	65	130	180	340	550	800
125	5	26	65	130	230	350	530	870	1010
150	6	35	90	200	360	640	900	1350	2100
200	8	43	180	350	580	1000	1600	3000	4000
250	10	125	360	660	1100	1800	3100	5300	6400
300	12	200	550	1000	1600	2600	5000	7500	8500
350	14	350	780	1400	2400	4000	8000	10800	11500
400	16	490	1050	1800	3100	5500	11000	12000	14500
450	18	510	1080	2040	3350	6100	11500	14600	20500
500	20	520	1100	2200	3500	6200	12000	15100	21000
600	24	750	1400	2800	5100	8800	14000	22000	29300